

Technology Focus Area **Carbon Sequestration/Separation**

The unique chemistry of the high efficiency carbonate fuel cell offers an innovative approach for separation of carbon dioxide from flue gas and other combustion exhaust gas mixtures. The simultaneous generation of power and CO₂ capture suggest an attractive scenario for re-powering the existing coal-fueled power plants. Development of this system is concurrent with emergence of internal reforming Direct FuelCell® (DFC®) technology for generation of electric power from fossil fuels. This technology is being deployed by FuelCell Energy, Inc. (FCE) in MW-scale power plants worldwide.

A simplified diagram of the system concept for combined CO₂ separation from flue gases and power generation is illustrated in Figure 1.

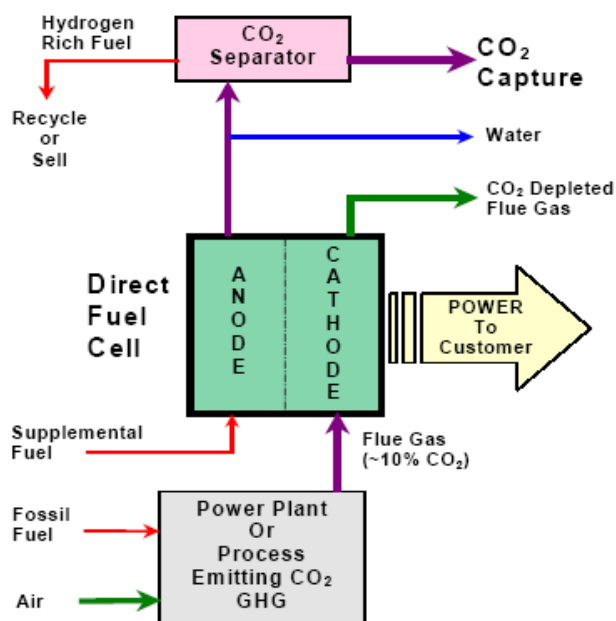

Figure 1. Direct Fuel Cell-based CO₂ Separation and Power System Concept:

This system can be used with a variety of CO₂-containing greenhouse gases

The CO₂-containing flue gas from coal-fired, combustion-based power plants, such as the exhaust from a pulverized coal power plant, is utilized as oxidant for the DFC® cathode. The DFC utilizes the CO₂ in the flue gas as a reactant for the electrochemical reaction to produce power, while synergistically transferring CO₂ to the anode exhaust stream. Natural gas, propane, or syngas can be used as the fuel cell anode feed to provide H₂ needed to complete the electrochemical power generation cycle.

The operating principle of DFC including the mechanism for transport of CO₂ from the cathode to the anode of the fuel cell is shown in Figure 2. In addition to CO₂, H₂O is produced at anode as H₂ is consumed by the electrochemical reaction. Overall, the operating mechanism of DFC results in the separation and transfer of CO₂ into the anode exhaust stream with a much-reduced flow compared to the original flue gas. Once separated, this greenhouse gas can be captured and sequestered, preventing its release into the atmosphere

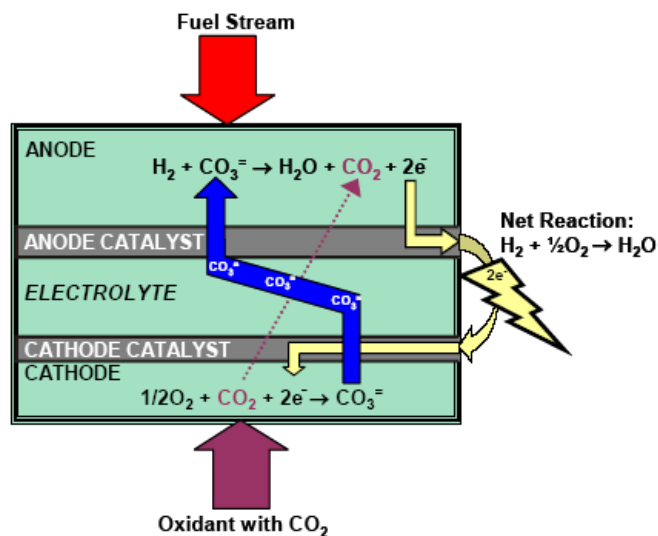

Figure 2. Utilization of CO₂ in a Direct FuelCell®: Carbon dioxide is used at the cathode as an oxidant and transferred to the anode via the carbonate electrolyte

In a cost shared US Department of Energy program, FCE has conducted preliminary feasibility studies to assess the DFC-based system concept for separation of CO₂. Development of the DFC® -based systems focused on integration of CO₂ separation systems with coal-based power plants which emit large amounts of green house gas. In parallel to system design and simulation activities, laboratory scale DFC® stack testing verified the concept and provided parameter input to the CO₂ separation system design. The system was studied to determine its effectiveness in capturing more than ninety percent of CO₂ from the flue gases. Preliminary cost estimate was performed for a 200 MW pulverized coal boiler steam cycle plant retrofitted with a DFC®-based CO₂ separation system producing an additional 130 MW of electric power. The estimated incremental cost of electricity increase due to CO₂ separation was below 35%.

Development of the DFC-based CO₂ separation system has also focused on evaluating the effects of coal flue gas contaminants on DFC performance and endurance, identifying acceptable contaminant levels for fuel cell feed, and selection or design development of the required clean-up equipment.

In March, 2011, FCE was granted a research award from the U.S. Environmental Protection Agency to evaluate the effectiveness of using Direct FuelCell® (DFC®) technology to efficiently separate CO₂ from the emissions of industrial operations such as refineries, cement kilns and pulp and paper mills. The research objectives are to determine cost and power output when utilizing the DFC-based carbon capture system with a variety of industrial flue gas composition.

Efficient and cost effective carbon capture has a large potential market globally.

Contact: Hossein Ghezel-Ayagh, 203-825-6048, hghezel@fce.com