

## **FUEL CELLS – CLEAN AND EFFICIENT POWER GENERATORS**

M. Farooque and H.C. Maru  
FuelCell Energy, Inc.  
3 Great Pasture Road  
Danbury, CT 06813

Fuel cell generators ranging from sub-kilowatt portable power units to multi-megawatt stationary power plants deliver clean and efficient power using a variety of gaseous and liquid fuels for residential, commercial, and industrial applications. Fuel cells produce electricity without combustion using very few moving parts, typically limited to air blowers and fuel/water pumps. Because of high fuel conversion efficiency, the flexibility to generate both heat and power, friendly siting characteristics, negligible environmental emissions, and lower carbon dioxide emissions, fuel cells are at the top of the list of desirable technologies for a broad range of power generation applications.

### **Fuel Cell Types**

Fuel cells facilitate electrochemical reactions of a fuel and an oxidant to produce direct current electricity without the conventional combustion reaction. A unit fuel cell is made up of an electrolyte member sandwiched between fuel and oxidant electrodes. Typically, the fuel is hydrogen, which is extracted from a fossil fuel for most common applications. The oxidant is typically oxygen supplied as air. The fuel is oxidized at the “anode electrode” releasing electrons to the anode, which move to the “cathode electrode” via the external circuit. These electrons reduce the oxygen at the cathode. The charged ions (positively or negatively charged) move across the ion conducting electrolyte member, completing the electrical circuit as illustrated in Figure 1. Fuel cells are commonly referred to by the electrolyte they use for internal transport of the charged ions.

The electrolyte that a fuel cell deploys determines its operating temperature. The electrolyte is also important from cell electrochemistry points of view. The main fuel cell types being developed are shown in Figure 1, identifying the electrode reactions, dominant charge transfer species, and the operating temperature. As can be seen, the Polymer Electrolyte Membrane (PEM) and Phosphoric Acid Fuel Cell (PAFC) involve  $H^+$  ion (cat ion) transport from anode to cathode where the product water is released. While Alkaline (AFC), Carbonate, and Solid Oxide fuel cells (SOFC) involve transport of a negatively charged ion (anion) from cathode to anode releasing water at the anode electrode. The cell operating temperature directly controls product characteristics as well as the system engineering.

The fuel cell reaction requires hydrogen, but it is not readily available and needs to be extracted from commonly available fuels for fuel cell use. The different gases present in the fuel stream affect the fuel cell performance. Depending on fuel cell type, some constituents work as fuel, but others may be inert, diluents, or a poison. The impact of the common gaseous fuel stream constituents on fuel cell performance is summarized in Table 1. The high temperature fuel cells are considered more flexible with respect to the common species present in the fuel streams.

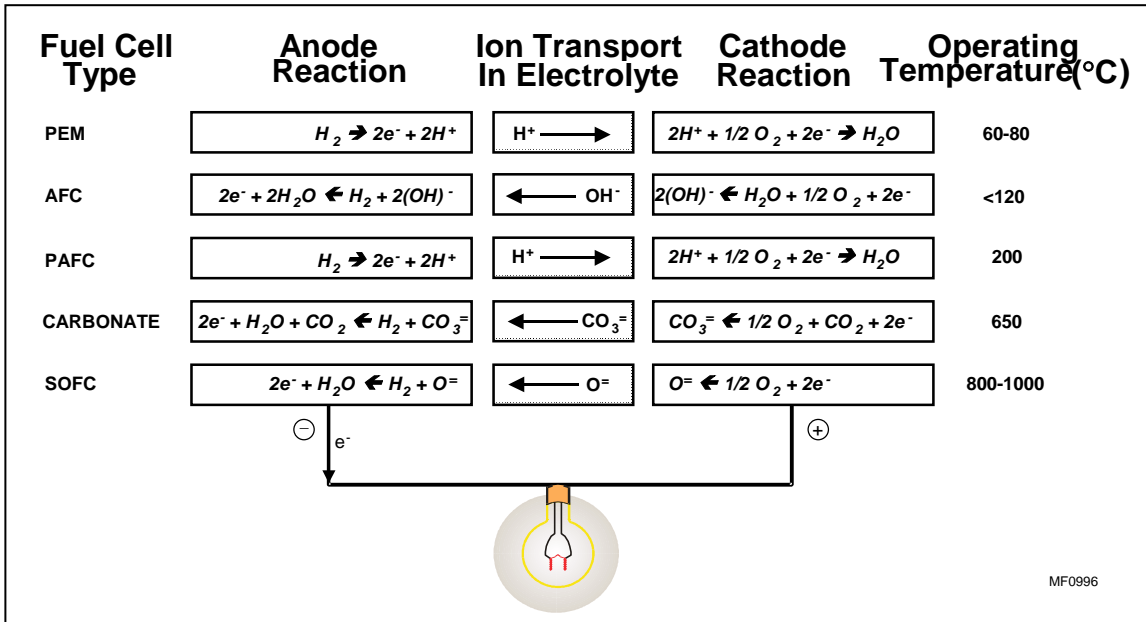

Figure 1. Schematic of Different Fuel Cell Types

Table 1. Impact of Major Fuel Constituents on Different Fuel Cells

Fuel Constituents	PEM	AFC	PAFC	Carbonate	SOFC
H <sub>2</sub>	Fuel	Fuel	Fuel	Fuel	Fuel
CO	Poison	Poison	Poison (>0.5%)	Fuel	Fuel
CH <sub>4</sub>	Diluent	Diluent	Diluent	Fuel <sup>a</sup>	Fuel <sup>a</sup>
CO <sub>2</sub>	Diluent	Poison	Diluent	Diluent	Diluent
N <sub>2</sub>	Diluent	Diluent	Diluent	Diluent	Diluent
S as (H <sub>2</sub> S & COS)	Poison	Poison	Poison (>50 ppm)	Poison	Poison
NH <sub>3</sub>	Poison	Inert	Poison	Fuel	No Information

<sup>a</sup> A fuel in the internal reforming fuel cells and a diluent in non internal reforming cells

### Fuel Cell Systems

A generic fuel cell system is described in Figure 2. The fuel choice is application-specific. The commonly available fuels need to be converted to fuel cell useable hydrogen. The conversion reaction is generally endothermic and requires catalysts. Steam reforming is a widely used process for converting hydrocarbon fuels to hydrogen. This reaction requires steam and heat, which are also fuel cell reaction products. The reforming reactions usually take place at a higher temperature than the fuel cell. As an example, external methane reforming is carried out at ~800°C. The operating temperatures of the different fuel cells result in significant variation in power plant configuration to accommodate the fuel processor. The low temperature fuel cells such as PEM and AFC need a higher temperature energy source to sustain steam generation and

reforming processes. The intermediate temperature fuel cell, such as the PAFC, can use its waste heat to raise the needed steam, but still needs a higher grade heat for the reforming reaction. Traditionally, an external fuel processor is used to generate hydrogen for low temperature fuel cell use (shown by dotted lines). Whereas, the high temperature fuel cells (Carbonate and SOFC) operate near or above the fuel processing temperature and can transfer heat from the fuel cell to the reforming site. This advantage has been used to incorporate the reformer function inside the fuel cell. The internal reforming design results in significant simplification in balance of plant (BOP) equipment design and higher system efficiency.

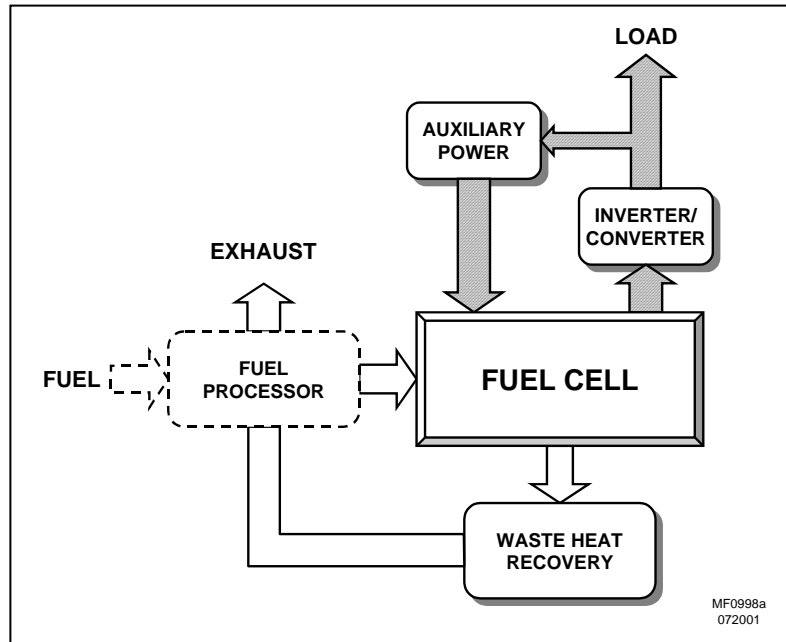

**Figure 2. Basic Fuel Cell System**

Individual fuel cells are connected in series (forming a “stack” of fuel cells), to deliver direct current at high voltage. The fuel cell stack is a variable current-voltage power source. Fuel cell output voltage decreases because of fuel cell internal impedance as more power is drawn. Also, the fuel cell internal impedance may slowly increase with aging, which is commonly known as voltage decay. Therefore, an appropriate power electronic subsystem is needed to condition the variable-voltage DC power to fixed voltage DC or AC power as required for an application. Each application has its own power electronics requirements with a common goal of high conversion efficiency and low cost.

The fuel cell is the most efficient energy conversion device known; therefore, it is desired that most of the available fuel be used in the fuel cell. However, practical considerations limit its utilization in fuel cells to 75-90%. The unused fuel as well as the heat generated by the electrochemical conversion process show up as a useable by-product heat source, which could be further used to enhance overall system efficiency.

The unutilized fuel in the gas leaving the anodes is typically oxidized for reforming or reactant preheating. Usable waste heat from a fuel cell power plant is usually available as sensible heat in the exhaust flue stream. Different approaches considered for utilization of the waste heat from various fuel cell types are summarized in Table 2. For low temperature fuel cells such as PAFC, waste heat is available at low temperature and can be used for raising low-pressure steam and/or hot water. It has also been considered for absorption chiller based air conditioning. On the other hand, in high temperature fuel cells, such as the Carbonate and SOFC, waste heat is available at high enough temperatures for raising high-pressure steam or other high value uses. Concepts have been developed to utilize the high quality heat from high temperature fuel cells in a bottoming cycle to augment the fuel-to-electricity conversion efficiency. Steam turbines, although less efficient than gas turbines, can be integrated with high temperature fuel cells to achieve high efficiency. Two concepts have been developed to integrate the most efficient Brayton cycle (gas turbine) with fuel cells to achieve ultra-high system efficiencies. The U.S. Department of Energy’s National Energy Technology Laboratory is supporting programs to develop and demonstrate this ultra-high efficiency fuel cell gas turbine power system for commercial applications.

**Table 2. Possible Utilization of Fuel Cell Waste Heat**

Fuel Cell Type	Operating Temperature	Waste Heat Utilization Options
PEM	80°C	Hot water
PAFC	200°C	Low pressure steam, hot water and air conditioning
Carbonate	600°C	High/low pressure steam and hot water Air conditioning, low pressure steam and hot water Organic Rankine cycle [3] Steam turbine Gas turbine
SOFC	800-1000°C	High/low pressure steam and hot water Air conditioning, low pressure steam and hot water Organic Rankine cycle Steam turbine Gas turbine

**Applications**

Each of the various fuel cell types can be configured in a system focusing on the market segments that match its characteristics most favorably. Figure 4 identifies the market segments currently being pursued by fuel cell systems, the cost goals for each of the markets, and the fuel cell types competing for a particular market. Because of their lightweight construction, compactness, and quick start-up potential, low temperature fuel cells are being considered for portable uses, residential power, and transportation applications. On the other hand, higher temperature carbonate and solid oxide fuel cells, which offer simpler and higher efficiency plants, are focusing on stationary power generation in the near term and large (10-50 MW) power plants in the long term. Generally speaking, all fuel cell systems use similar balance-of-plant components. The balance of plant equipment contributes a larger fraction of the fuel cell plant cost. High temperature fuel cells offer simpler balance-of-plant due to ease of fuel

processing. It is generally believed that smaller fuel cell systems face a greater cost challenge due to unfavorable economy of scale of balance-of-plant equipment. Wide market penetration and high volume mass production will be required to overcome this cost challenge.

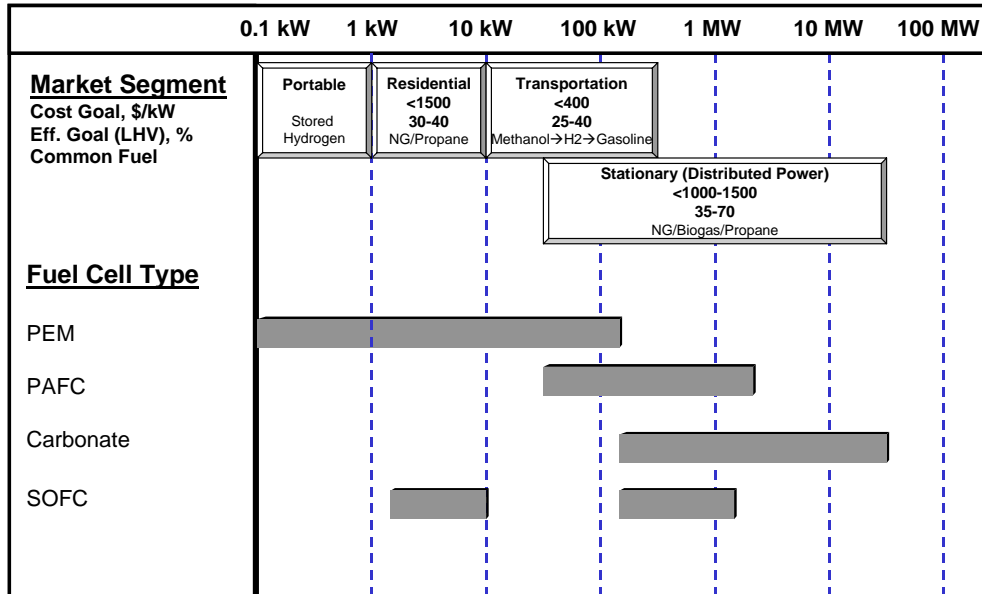

**Figure 4. Fuel Cell Generators Under Development and the Current Targeted Markets**

**PEM Fuel Cell:** The polymer electrolyte (PEM) fuel cell uses a proton conducting membrane sandwiched between two platinum-based porous electrodes and operates at a low temperature ~80°C. This allows for faster startup, non-metallic construction, and minimal insulation, resulting in compact and lighter packaging. However, very little cogeneration potential is available because waste heat is rejected at slightly above room temperature. The PEM fuel cell is seen as the system of choice for portable, vehicular, and residential applications. It is also being developed for smaller scale stationary power. The technology challenges relating to low temperature operation include water management, heat removal, and anode poisoning by trace amounts of CO present in hydrocarbon-derived fuels.

The small portable and mobile PEM fuel cell power sources are being developed to replace batteries in longer duration power source applications. These units are usually fueled with compressed hydrogen cylinders or metal hydrides. Technical barriers to PEM fuel cells for the hydrogen fuel system seem to have been overcome. Cost reduction is expected as the technology matures with experience and a wider market penetration.

The promise of fuel cells as an environmentally superior and more efficient automobile engine has generated unprecedented public and organizational support to develop the PEM automobile engine. This fuel cell automotive transmission system consists of fuel cell stacks, fuel processor and the integrated electrical system. Major efforts are underway in North America, Europe, and Japan to develop all aspects of the technology. Major automobile manufacturers have publicly committed to have production-ready fuel cell electric vehicles in two to six years.

The PEM fuel cell runs on pure hydrogen, therefore, it must have a fuel processor capable of converting gasoline, diesel or methanol into a CO-free and hydrogen-rich fuel gas that can be used by the PEM stacks to generate power. The fuel processor usually operates at high temperatures, 800-900°C for gasoline reforming. The CO level is required to be reduced to low, ~10 ppm range to avoid anode poisoning. As a result, all fuel processor types comprise multiple process units and involve extensive thermal integration, adding complexity and cost to the system. The leading programs have demonstrated proof-of-concept fuel processors and are trying to meet all criteria, including rapid cold start, which is important for automobile applications. In the US, gasoline is emphasized as the fuel for the automobile fuel cells. Because of difficulties with sulfur cleaning requirements for the fuel processor catalyst and processing, a cost-effective technology may not be available in the near term. The hydrogen-air PEM fuel cell has shown its technical readiness for the fuel cell electric vehicle engine. However, hydrogen is not a readily available fuel currently or in near term. Methanol is a clean fuel and is much easier to process than the gasoline and diesel fuels. Efforts are underway to develop a fuel cell design that will allow operation on direct methanol.

PEM fuel cell based power sources are also being developed for residential (3-7 kW) and building (50 kW) electricity and hot water applications. Pipeline natural gas and propane are the two important fuel choices for these applications. Residential units are in prototype field trial and commercialization is targeted for 2002. The U.S. Department of Energy's Office of Energy Efficiency and Renewable Energy is sponsoring research and development of fuel cell power system technology for building electricity and hot water application with an efficiency and cost target of >35% (LHV), and <\$1500/ kW. A 250 kW size PEM power source of the type developed by Ballard Power Systems, Vancouver, Canada is also being considered for the distributed power generation in buildings. Four units have been delivered recently for field trials.

**Alkaline Fuel Cell:** The AFC is one of the earlier fuel cell systems employed for special applications. It uses an aqueous solution of the KOH electrolyte. The operating temperature depends on KOH concentration, <120°C when the KOH concentration is 35-50 wt %. AFC reactants are limited to pure hydrogen, and pure oxygen or CO<sub>2</sub>-free air. The AFC provides excellent performance on oxygen and hydrogen compared to other fuel cells. NASA uses it in the space shuttle orbiter to provide on-board electric power and water. However, NASA seems to have a plan to replace the alkaline fuel cell with the PEM fuel cell system. Like the PEM fuel cell, CO is considered a poison in the alkaline fuel cell. The AFC is extremely sensitive to CO<sub>2</sub> because it reacts with and consumes the alkali in the electrolyte. Even the small amounts of CO<sub>2</sub> in ambient air, the source of O<sub>2</sub> for the fuel cell reaction, react with the electrolyte and need to be removed for the alkaline fuel cell. The AFC is believed not to be cost-effective for most commercial applications because of the requirement for scrubbing the small amount of CO<sub>2</sub> within the air, and the need for purification of the hydrogen derived from fossil based fuels. Its uses have been limited so far to closed system applications. However, developments in hydrogen storage systems and alternate cell designs have generated renewed interest in this fuel cell type for terrestrial portable power applications.

**Phosphoric Acid Fuel Cell:** The phosphoric acid electrolyte fuel cell operates at about 200°C and is capable of operation on ambient air and CO<sub>2</sub> containing hydrogen stream. The PAFC can not utilize CO contained in a fuel, but, unlike the PEM and AFC, it can tolerate CO in low concentration with minimal performance penalty. Therefore, it can operate on hydrocarbon-derived fuels. Like the PEM fuel cell, it uses noble metal catalysts for both the electrodes. The

fuel cell waste heat is rejected at high enough temperature to heat water and raise low pressure steam, but not high enough to be utilized for a bottoming cycle power generation. The fuel cell operating temperature does not support internal reforming of common fuels, such as natural gas. An external reformer that operates at higher temperatures than the fuel cell is used to convert the hydrocarbon fuel to hydrogen, affecting the overall system efficiency.

The PAFC is the one of the earliest fuel cell generators introduced commercially, starting in 1992. The 200 kW size units are available for stationary power and heat applications. These units are designed to provide 37% (LHV from natural gas) electrical conversion and 87% overall thermal efficiency in combined heat and power applications. More than 200 units have been delivered to customers in 15 countries on four continents. One of the units has achieved more than 49,000 hours of operation in Japan. The cost of these early units seems to be about three times higher than the mature commercial goal. The limitation of the PAFC for high value utilization of waste heat, dependence on noble metal catalyst, and moderate electrical conversion efficiency has provided the incentive for development of alternate high temperature fuel cells.

**Carbonate Fuel Cell:** The electrolyte in this fuel cell is a mixture of alkali carbonates. The carbonate ions provide the electron transport (as charged ions) between the electrodes. Carbonate fuel cells operate at 550-650°C. Noble metals are not required; both electrodes are based on nickel and the reactions are very fast. The CO can be utilized as a fuel in this fuel cell. An advantage of the carbonate fuel cell is that it operates more efficiently than other fuel cells with CO<sub>2</sub> containing bio-fuel derived gases. Performance loss on the anode due to fuel dilution is compensated by cathode side performance enhancement resulting from CO<sub>2</sub> enrichment. The operating temperature allows internal reforming of most of the gaseous and liquid fuels. Simple and highly efficient power plant systems can be configured using the carbonate fuel cell. Corrosion of cell hardware is a design consideration. Endurance results have shown that the properly engineered stainless steel cell hardware provides adequate corrosion protection. Alternate cathode materials are being developed, particularly for high-pressure systems to prevent accelerated corrosion that may occur under such conditions. The carbonate fuel cell, essentially constructed from stainless steel, is generally heavier than other fuel cell types.

Because cell construction employs commonly available stainless steels, electrode materials are based on nickel, and well-known manufacturing processes are employed, carbonate fuel cells are expected to be cost competitive with the presently used rotating machine based power generation systems. System simplicity and 550-650°C operating temperature allow competitive cost of balance-of-plant equipment. With an installed cost goal of 1250–1500 \$/kW, the carbonate system is expected to generate electricity with 5-7¢ kWh depending on fuel cost and other parameters.

**Solid Oxide Fuel Cell:** The electrolyte in this fuel cell is an oxygen ion conducting solid nonporous ceramic, usually Y<sub>2</sub>O<sub>3</sub> –stabilized ZrO<sub>2</sub>. The present day SOFC cells operate at 800-1000°C, which is high enough to allow internal or indirect reforming of the hydrocarbon fuels. The electrodes are also made of ceramics. The ceramic construction of the cell components alleviates possible corrosion issues associated with high temperature operation. The kinetics of the fuel cell reactions is fast. CO also functions as a fuel in SOFC. The high temperature operation and solid construction require that the thermal expansion coefficient of the cell components be matched closely. All-ceramic construction also requires special design consideration to optimize cell internal resistance. The tubular-shaped cell connection has been

developed to facilitate electrical connection between cells as well as to impart thermal cycling robustness. Performance, thermal cycleability, and stable operation of this design have been demonstrated at the proof-of-concept level at customer site tests. The planar ceramic fuel cells offer additional challenges with respect to heat, mechanical stress, and seal management. The engineering solutions associated with the planar ceramic fuel are evolving, and testing of pre-prototype designs has begun.

Considering the manufacturing cost implications of all-ceramic hardware fuel cells, efforts are underway to develop intermediate temperature, 600-800°C, solid oxide fuel cells so that the lower cost conductive metallic components could be used for cell hardware. The intermediate temperature operation will also improve the stability of the electrodes and cell interconnect materials. However, the electrodes and the electrolyte need to be further optimized to attain performance goals. A major initiative, known as the Solid State Energy Conversion Alliance (SECA) has been launched under the guidance of the National Energy Technology Laboratory (NETL) to develop the low-cost SOFC fuel cell system for a broad range of applications. SECA is structuring several industrial development teams, each supported by a crosscutting technology program with participation by universities, national laboratories, and other research organizations. It is envisioned that the mass producible SOFC system will be available from these efforts at less than \$400/kW for stationary applications and at even lower costs for transportation applications.

## **Benefits**

*Fuel cell generators are highly efficient and exceptionally clean.* The efficiency comparison of some of the fuel cell systems with other electric power plants can be seen in Figure 5. The Direct FuelCell (DFC<sup>®</sup>), an internal reforming version of the carbonate fuel cells, produces electricity with an efficiency approaching an unprecedented 60% (LHV) in simple cycle MW size systems. Also, most fuel cell systems project >80% (LHV) efficiency in combined heat and power applications. Electrical conversion efficiency approaching 75% (LHV) is possible for multi-megawatt combined cycle fuel cell power plants. High temperature fuel cells are believed to have a 20-30% chemical-to-electrical energy conversion efficiency advantage over the present rotating-machine-based systems smaller than 50 MW sizes. Fuel cell performance depends on the “chemical value” of a fuel (amount of hydrogen available from a fuel after reforming) and not on the heating value. Therefore, efficiency advantage of the fuel cells compared to heat engines increases when operating on medium- and low-heating value fuels, such as biomass-derived renewable fuels, landfill gas, digester gas, etc. Contrary to the heat-engine-based power plants, fuel cell power plant performance is essentially unaffected by ambient temperature and altitude. A comparative example is shown in Figure 6. Fuel cells also maintain their high efficiency at part loads. Therefore, fuel cells hold a great promise to help conserve the finite hydrocarbon fuel resources of the world while reducing the carbon dioxide emissions.

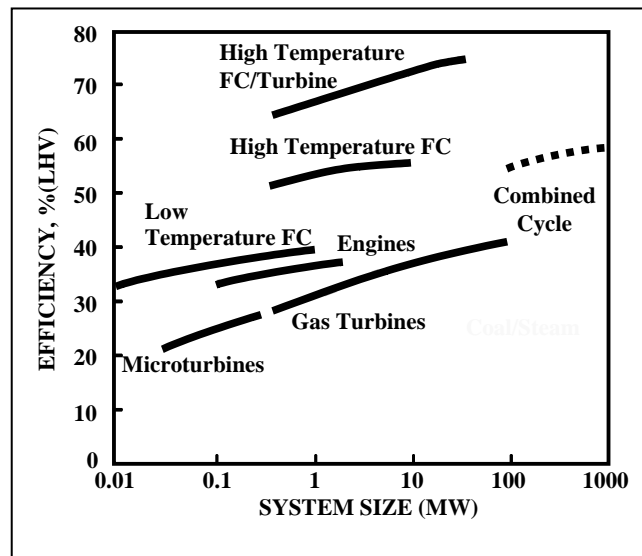

**Figure 5. Electrical System Efficiencies of Fuel Cells Compared with Other Electric Power Plants**

*Fuel cells are an extremely low NO<sub>x</sub> producing power source.* Unreacted fuel is usually catalytically combusted to produce heat for recovery or for external reforming. This catalytic combustion of low-heating-value fuel produces a negligible amount of NO<sub>x</sub>. A comparison of environmental emissions of different fuel cell technologies is presented in Table 3 with other technologies available for the stationary applications. Fuel cell NO<sub>x</sub> emissions are at least an order of magnitude lower than the alternate systems. The NO<sub>x</sub> is reacted in the carbonate fuel cell; therefore, it emits the least NO<sub>x</sub> among the fuel cell generators, about one one-hundredth of present day systems.

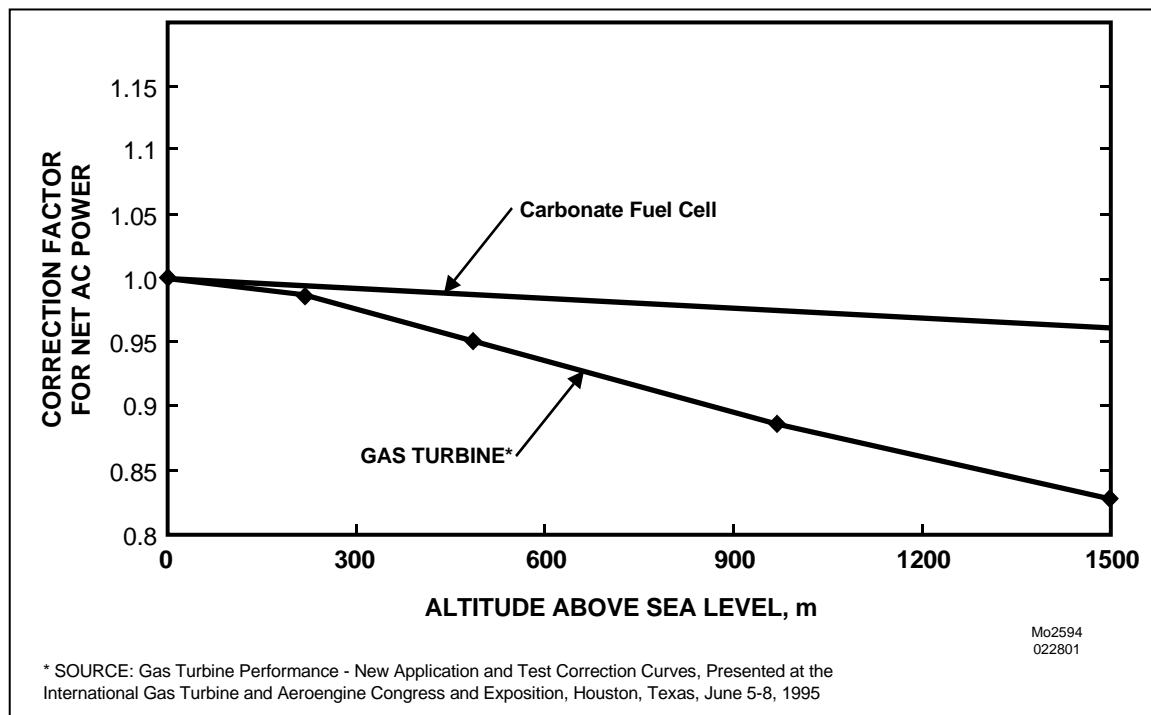
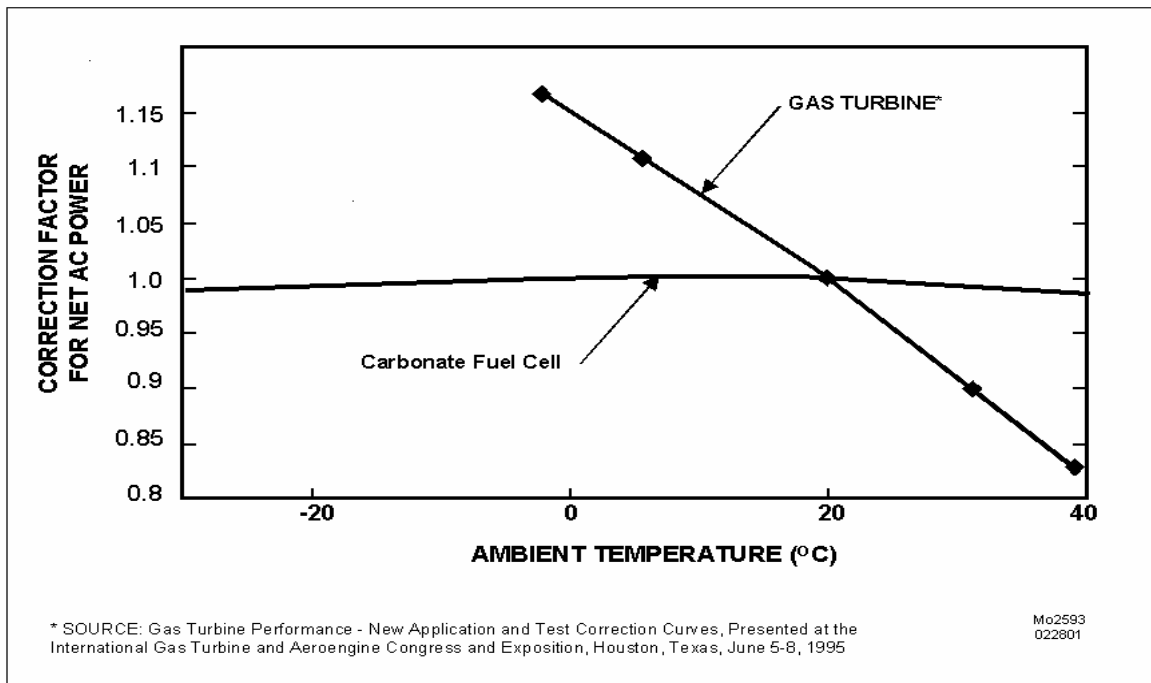

**Figure 6. Comparative Example of Relatively Negligible Effects of Ambient Temperature and Altitude on Fuel Cell Performance**

**Table 3. Emissions Comparison of Different Distributed Generation Technologies**

Items	Engine Generator	Turbine Generator	Micro Turbine	Fuel Cells	
				PEM	DFC <sup>®</sup>
Capacity Range	50kW-5MW	500kW-25MW	30-75kW	<1kW-250kW	250kW-3MW
Efficiency, % HHV LHV	28-42 <sup>[a]</sup> 31-47	21-40 <sup>[a]</sup> 23-44	25-30 <sup>[a]</sup> 28-33	<36 <40	50-54 55-60
NO <sub>x</sub> (lb/MWh) Natural Gas	>3.0 <sup>[b]</sup>	1.1-0.6 <sup>[b]</sup>	0.5-1.4 <sup>[b]</sup>	0.02	<0.002 <sup>[c]</sup>
CO <sub>2</sub> (lb/MWh) <sup>[d]</sup> Natural Gas	1410-940	1880-990	1580-1310	>1130	790-730
SO <sub>x</sub> (lb/MWh) <sup>[d]</sup> Natural Gas	0.012-0.008	0.016-0.008	0.013-0.011	0.0002	0.0001

- “The Distributed Power Generation Puzzle: Piecing it Together”, Power Engineering, April 2000.
- Capstone Turbine Corporation White Paper (<http://www.capstoneturbine.com>).
- Derived from FCE internal testing.
- Derived from a natural gas reference spec (assumes: 6-ppm sulfur in natural gas, cleaned to 100 ppb for reformer, LHV 933 Btu/scf; HHV 1035 Btu/scf).

*Fuel cells produce exceptionally low SO<sub>x</sub>.* Average sulfur content in the U.S. natural gas pipeline is in the range of 6 ppm. Conventional power generators convert this sulfur to SO<sub>x</sub> in the combustion reaction and emit it into the atmosphere. Sulfur is a poison to the reforming catalyst; therefore both external and internal reforming fuel cells require that sulfur be removed to <0.1 ppm for use in the reformers. Therefore, sulfur compounds present in the fuel stream are removed before being introduced into the fuel cell. As a result, sulfur emissions from fuel cell generators is almost non-existent compared to the other generators. The simple cycle fuel cell generator uses as few as one blower and one water/fuel pump and no large rotating turbine. Therefore, it has very low noise signature.

*Fuel cell generators offer significant siting flexibility and easy regulatory approval* because of the above environmental attributes. In fact, because of these environmental benefits, California clean-air regulators allow fuel cell power plants to bypass traditional permit requirements.

*Since fuel cell systems have very few rotating parts, they are quiet, reliable, and require less maintenance than the internal combustion based power generation systems.* Fuel cells are efficient even in small sizes. Therefore, they can be located at the load sites. Load growth can be met by simply adding units as demand for power increases. Fuel cell systems are being developed for unattended, remotely controlled, automatic operations. These features, coupled with grid-independent operation capability, provide fuel cells unlimited opportunities in onsite power generation applications.

## Power Electronics for Managing Fuel Cell Power

Fuel cell produced variable voltage DC power is conditioned by appropriate power electronics to suit the requirements at the point of delivery. Performance (control of output voltage and current, current harmonics distortions, low acoustic noise, no outage, and no electromagnetic interference), efficiency, and cost of the power electronics system are important considerations for the commercialization of fuel cell power sources. Fuel cell generators are being considered for grid-connected (also called grid-parallel), grid-connected islanding (provide power to local loads at the time of grid outage), grid-independent (also called stand-alone), as well as grid-linked (allowing power import but not export to grid) operations. These operating options are schematically described in Figure 7.

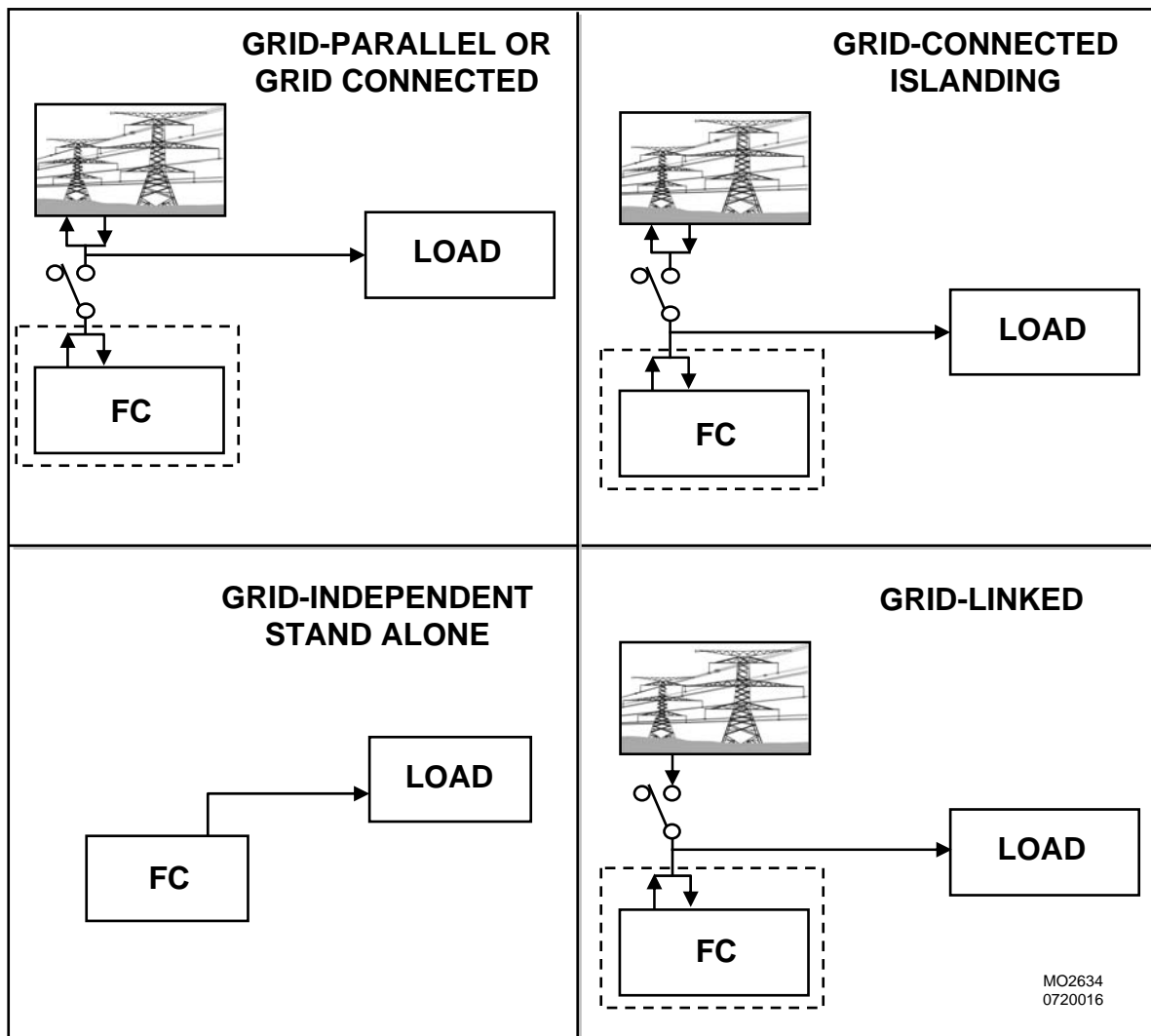

**Figure 7. Schematic Illustrating Various Fuel Cell System Power Electronic Configurations**

Grid-parallel power generation applications require that the AC power is supplied at the grid distribution voltage and frequency, meeting grid power quality for voltage and current waveform harmonic distortions as specified by IEEE Standard 519. The DC to AC converter output current is usually controlled to deliver power to a load, based on demand. It also provides the ability to regulate reactive power production, both in magnitude and direction, independent of the real power. The imaginary power dispatch ability for the grid VAR control is considered an added feature of the fuel cell system. Safety considerations, particularly for linemen who may be working on the system during a grid outage, require that appropriate contactor and sensors are included to disconnect the generator after a fault has been detected. In the grid-connected power export-only mode operation, the power plant stops power production and is switched to the idle or parking mode when grid outage occurs. However, in the grid-connected islanding operation, the fuel cell source is disconnected from the grid at the time of grid outage, but may continue to provide power to its dedicated local load. The islanding option allows power delivery to the local critical load during grid outage. This is considered a high value feature of the fuel cell system. In the grid-independent operation, the fuel cell generator requires its power electronics to deliver power at the voltage and frequency required by the local load. In the grid-linked operation, a stand-alone unit can draw power from the grid but has no means to send power to the grid. This capability also allows a stand-alone fuel cell system to operate at the base load and draw peak power from the grid. The grid-connected islanding and grid-linked operation features allow the fuel cell systems to be configured into an uninterruptible power supply (UPS).

### **Development of Codes and Standards for Fuel Cells**

Fuel cell generators are moving from research-based prototype installations to commercial, industrial, and residential markets. Existing codes and standards in many cases may not recognize the specific features of the fuel cells. It is desirable that the fuel cell generators be recognized by international, national, and local level codes to facilitate rapid market penetration. The whole process of codes and standards development involves building a consensus on the standards, recognition of standards in the code (by reference), and training of code enforcing authorities/adopters. To facilitate this process, the U.S. Department of Energy, working with the U.S. fuel cell industry, has been fostering the development and adaptation of codes and standards that will support commercial entry of the fuel cell generators. These codes and standards pertain to design, manufacture, installation, performance verification, and safe operation of fuel cell systems. Status of fuel cell related codes and standards is summarized in Table 4.

### **Outlook**

The increasing energy demand and cost, growing public awareness for energy conservation, and concern for global warming and smog-causing emissions from power plants and automobiles have set the stage for commercial entry of fuel cell power sources. Fuel cells promising better than 20% energy conservation, a similar amount of carbon dioxide emissions reduction from power plants, and an order of magnitude reduction in smog-causing precursor emissions, are entering the commercial market.

**Table 4. Status of Fuel Cell Standards Development**

Standard	Description/Comments	Status
ANSI-Z21.83 Stationary Fuel Cell Power Plants	This national standard for fuel cell power plants is intended for packaged power plants operated on a gaseous hydrocarbon with output not exceeding 600 volts and 1,000 kilowatts. The standard addresses construction, performance and quality assurance, and will be used for ‘testing and listing’ to address state and local codes that require equipment to be so evaluated.	The standard has been published and is available through International Approval Services at (216) 524-4990.
NFPA 853 Installation of Stationary Fuel Cell Power Plants	Scope covers safe installation of Fuel Cell Power Plants > 50 kW. The standard provides fire prevention and fire protection requirements associated with buildings or facilities employing stationary fuel cell power plants.	Published and ready for reference in appropriate building codes
NES Protocol Fuel Cell Installations	National Evaluation Service is developing an evaluation protocol by which stationary fuel cell power plants can be evaluated relative to compliance with adopted codes and standards, with a focus on building codes.	Under development
IEEE P1547 Distributed Resources Interconnected with Electric Power Systems	Provides uniform standard for interconnection of distributed resources (fuel cells, PV’s etc) with electric power systems. Focus is on interconnection protection and design requirements.	Final draft being prepared for final committee ballot
UL 1741 Standard for Evaluation of Inverters, Converters, Controllers for Use in Independent Power Systems	Requirements are being added to this original photovoltaic standard to cover fuel cell and rotating machine inverters, converters and utility interaction controllers.	The published standard has been harmonized with IEEE 929 and will be harmonized with IEEE 1547 when 1547 is published.
ASME PTC 50 Performance Test Code for Fuel Cell Power Systems	Covers Test Procedures, Methods, and Definitions to Address Performance Characterization of Fuel Cell Systems	Work Continues. Publication Target Date 2002.